

# DRAIN AND SEWAGE LIFTING UNITS



## MP250 PRODUCT PICTURE



# EXPLOSION DIAGRAM

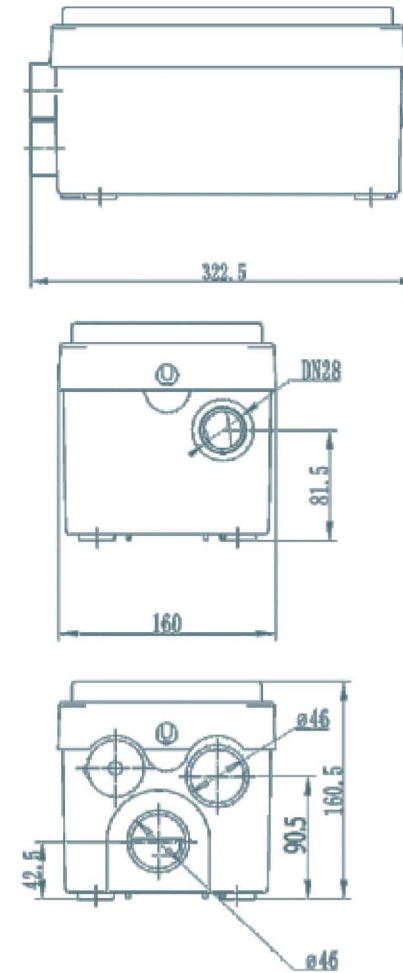

# PRODUCT PICTURE

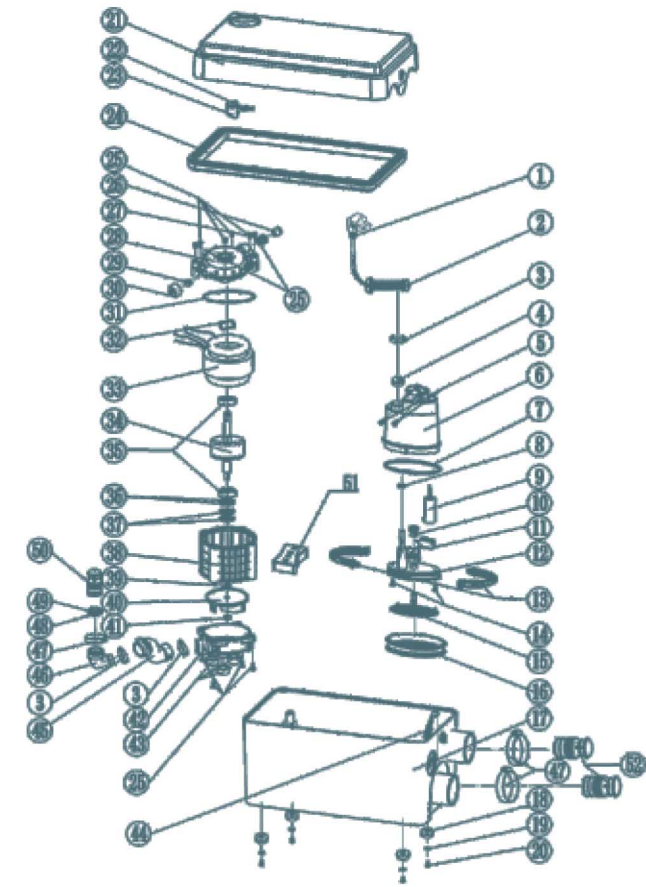

# PRODUCT PATAMETERS

## MP250

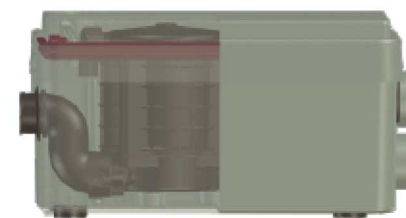

- 250w
- 50m
- 22-32mm
- H05VV-F 3G  
0.75mm<sup>2</sup>×1.2m
- 5m
- 40°C
- 1328pcs  
/20'ctn
- 4.4/4.8kg  
19.2/20.6kg
- 80l/min
- 2
- 33.5×20×25.5cm  
41.5×35.5×54cm/4pcs