

Arun Pivoting Mirror Cabinet



CONTACT DETAILS

UK: Croydex, Central Way, Andover, Hampshire, SP10 5AW, UK
EU: MIL, Unit 8 Purcellsinch Ind Est, Dublin Road, Kilkenny, R95 HP71, Ireland

Tel: +44 (0)1264 365 881 Email: info@croydex.co.uk Web: www.croydex.co.uk



ALWAYS CHECK THE PACKAGING FOR FIXINGS AND PARTS BEFORE THROWING AWAY AND RECYCLING.

ENSURE YOU HAVE ALL THE FIXINGS AND PARTS BEFORE ATTEMPTING TO ASSEMBLE OR FIT THIS PRODUCT.

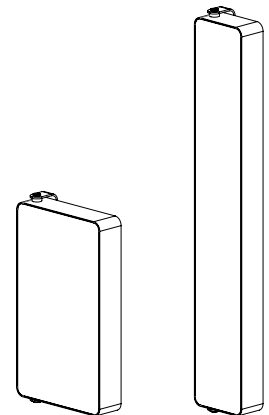

- Always follow the instructions provided to ensure that your product is assembled and fitted safely, and retains its high quality finish.
- Before attempting to fit or use this product, ensure that it can be properly installed in the desired location.

PLEASE RETAIN THIS MANUAL FOR FUTURE REFERENCE

This installation guide applies to the following products:

WC8801## - Arun Large Pivoting Mirror Cabinet

WC8802## - Arun Tall Pivoting Mirror Cabinet

Tools Required - not supplied

Cross head screwdriver, Large flat head screwdriver, Pencil, Spirit level, Drill, 8mm Masonry drill bit, 8mm Ceramic drill bit (Optional)

KEEP DIY TOOLS OUT OF THE REACH OF CHILDREN

Home Safety Advice

- It is recommended that two people fit this product to ensure that it is fitted safely.
- **Always** take care when using power tools, particularly if there is any water in the working area.
- **Always** check for hidden cables and pipework before drilling and take extreme care if there is any water in the working area.
- **Always** use a residual current circuit breaker (RCCB).
- **Always** wear suitable eye protection when drilling.
- **Do not** use a hammer drill when drilling through tiles.
- **Always** use a drill bit that is suitable for the surface that is being drilled.
- **Do not** use power tools for assembling the product including power drills and power screwdrivers.
- **Do not** overload the cabinet, maximum safe working load per shelf is 2kg evenly distributed.
- **Do not** strike the product with hard or sharp objects.
- **Do not** place hot objects onto shelf surfaces.
- **Do not** position in close contact with a heat source.
- Periodically check that the two pivot nuts are tight and have not loosened during use.

Product Care

- To retain the best quality finish, clean product regularly with a soft cloth and mild detergents.
- Do not use abrasive or chemical cleaners as these will damage the product.
- Spray cleaning liquids onto the cloth and not directly onto the backing panel or painted steel shelves.

Pack Contents (Not to scale)

WC8802##

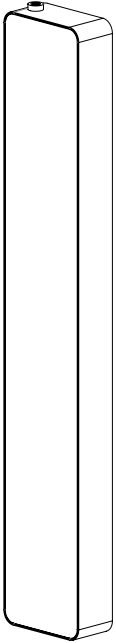

A Cabinet Assembly x 1

WC8801##

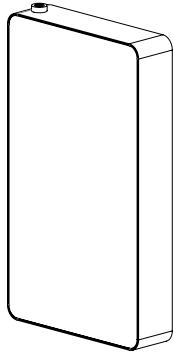

WC8802##

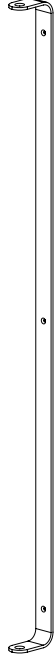

B Wall Bracket x 1

WC8801##



C Pivot Nut (with rubber o-ring fitted) x 2

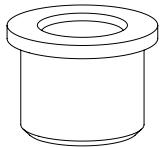
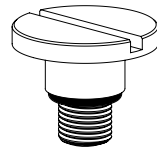

D Plastic Collar x 2

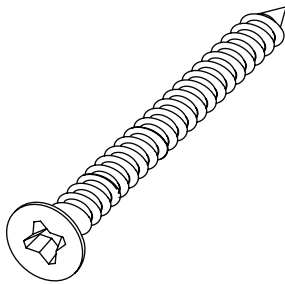

E Wall Screw x 3

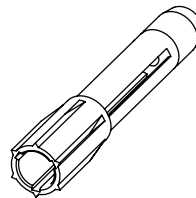

F Wall Plug x 3

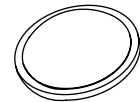

G Rubber Buffer x 4

Assembly Instructions

1. Carefully remove the cabinet and wall bracket from the outer packaging.
2. Place the wall bracket (B) against the wall in the desired location of the cabinet ensuring that there is a clear space either side of the wall bracket of 200mm if you are fitting the tall cabinet (WC8802##), or 350mm if you are fitting the large cabinet (WC8801##), See Fig 1. This is the space required by the cabinet as it rotates on the wall bracket. Ensure that there are no obstructions within these areas as this will limit the rotation of the cabinet.
3. Ensure the wall bracket is vertical using a spirit level and mark through the three holes onto the wall with a pencil. Fig 2.
4. Using a 8mm masonry drill bit, drill the holes in the marked positions to a depth of 50mm. If drilling through tiles, pre-drill using a ceramic drill bit.

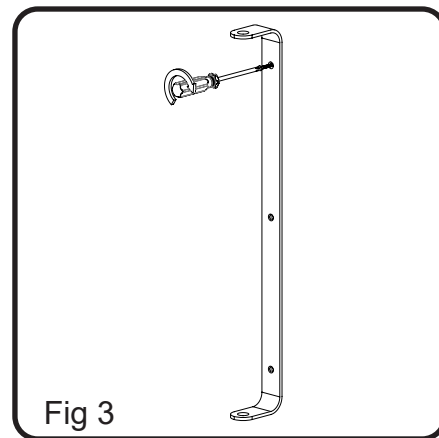
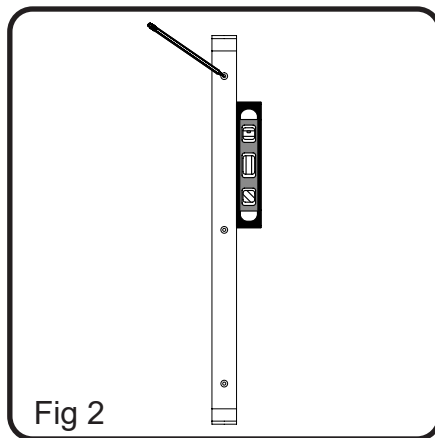
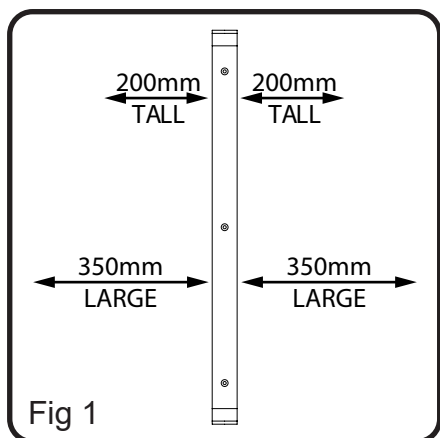

5. Insert the wall plugs (F) flush to the surface of the wall, if fitting to a tiled surface the wall plugs should be inserted below the surface of the tile to avoid cracking.
6. Screw the wall bracket securely to the wall using the three wall screws (E). Fig 3.
7. Carefully position the cabinet assembly (A) into the wall bracket so that the two protruding circular bosses on the top and base of the cabinet line up with the two large holes on the top and base of the wall bracket. Fig 4.
8. Once the holes are aligned, place a plastic collar (D) into each hole and push through until they are fully located into each circular boss, securing the cabinet assembly. Fig 5.
N.B. The cabinet can be mounted as a left or a right hand side opening as desired by simply rotating the orientation of the cabinet assembly before it is located into the wall bracket.

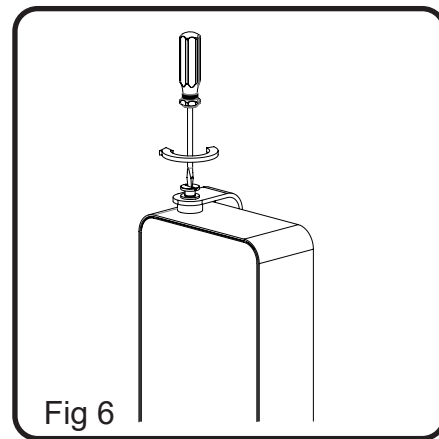
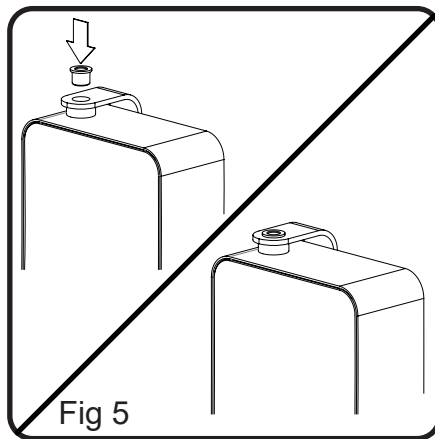
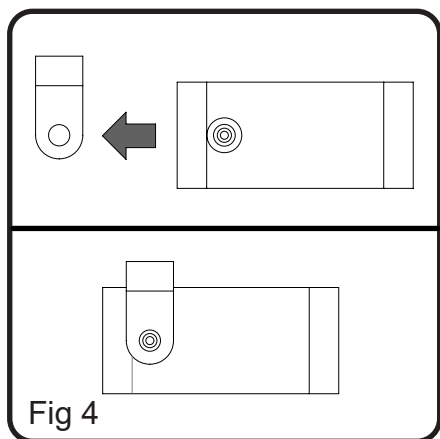

IMPORTANT SAFETY NOTE:

Before proceeding ensure each pivot pin (C) is fitted with a small rubber o-ring at the base of the threaded area. If the o-rings are not fitted please follow the diagram below for correct fitment.

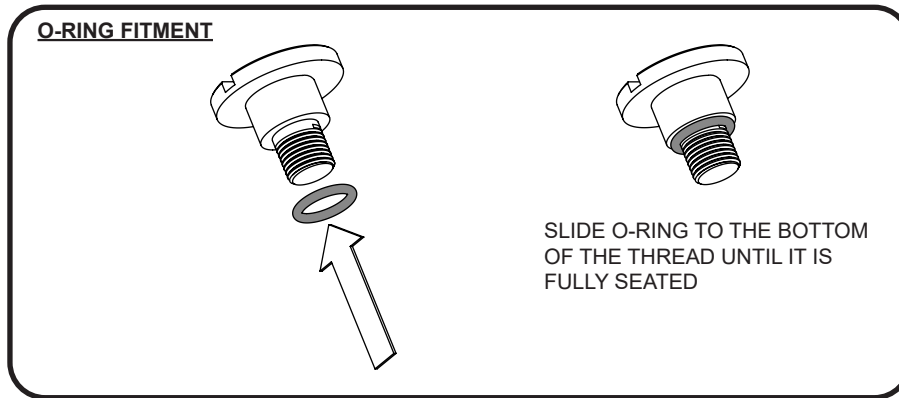

- 9. Screw one pivot pin (C) through the plastic collar on the top wall bracket into the circular boss on the cabinet assembly and tighten using a large flat head screwdriver to fully secure the cabinet. Repeat this for the bottom fixing. Fig 6.

- 10. This cabinet has been supplied with four self adhesive rubber buffers (G) which can be used to cushion the cabinet from any potential contact made with the wall when it is rotated on the wall bracket. If you wish to use the rubber buffers it is suggested that a rubber buffer is placed on the front outer edge of each of the two inner most shelves. Fig 7. If desired, the two remaining rubber buffers can be stuck to the wall anywhere along the line where the edge of the cabinet makes contact with the wall when it is in its fully opened position. Fig 8.

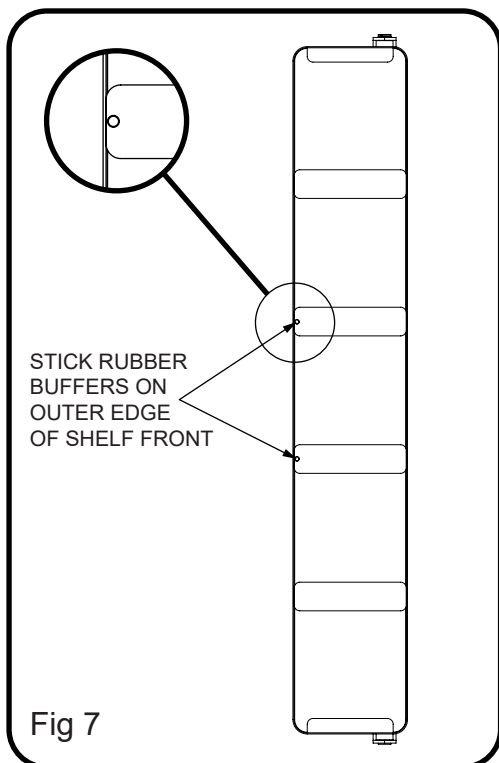

Fig 7

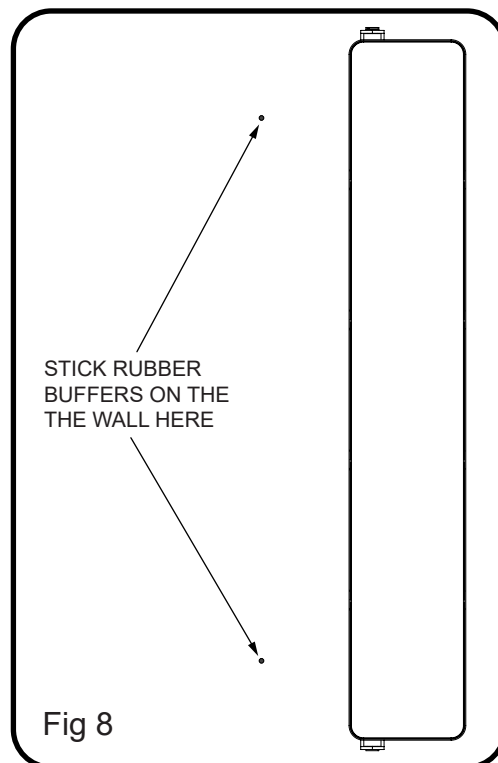

Fig 8