

Close Coupled Toilet and Cistern

- Toilet pan, seat and cistern are supplied in three separate boxes
- Waste pipe (pan connector) sold separately if a new installation

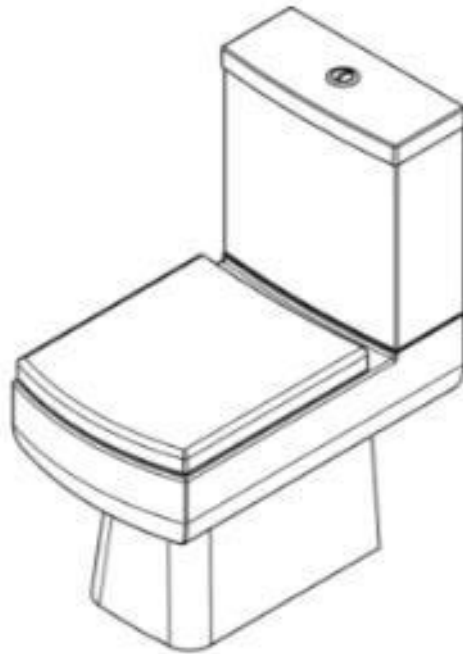

Please note: Image is for illustrative purposes only and may differ slightly to the actual product

Contents

- Parts
- Tools required
- Installation
 - Pan Connector
 - Close coupled Toilet Pan Fitting
 - Preparing the Cistern
 - Re-fitting the Toilet Pan
 - Fitting the Push Button
- Troubleshooting
- Maintenance
- Cleaning

Parts

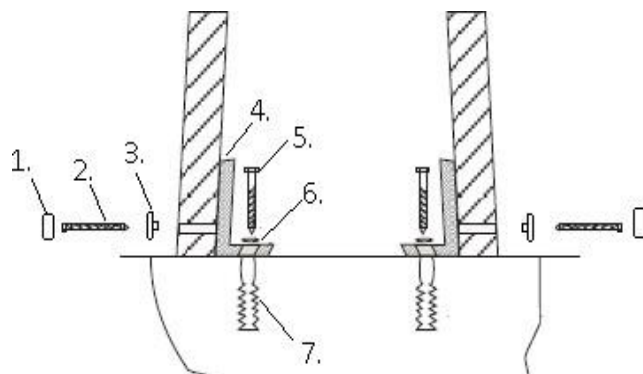

Toilet Pan (number 10 below)

Seat

Floor fixing kit (below components)

1. Screw cover
2. Bracket to pan fixing screw
3. Screw cup
4. Floor fixing 'L shaped' bracket
5. Floor screw
6. Screw washer
7. Screw plug

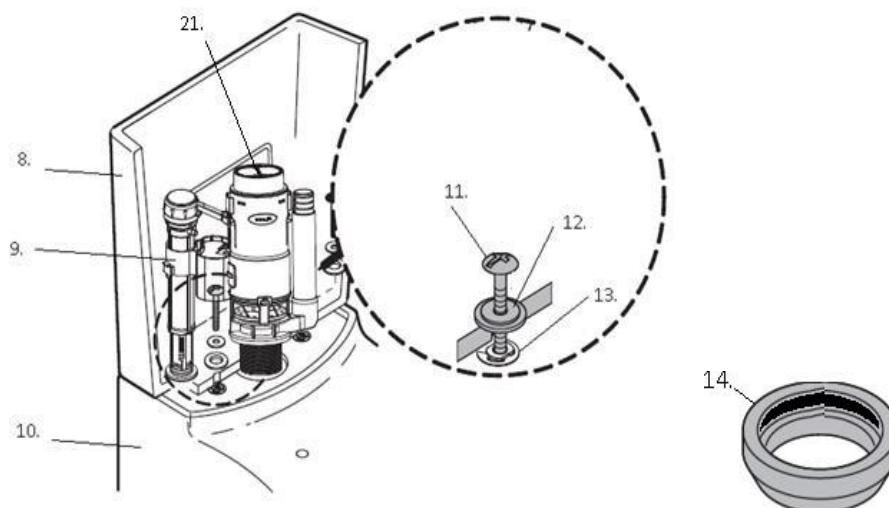

Cistern (components below)

8. Cistern tank
9. Inlet valve including washer, seal and nut
10. Toilet Pan
11. Cistern bolt

- 12. Cistern bolt seal
- 13. Cistern bolt nut
- 14. Doughnut washer

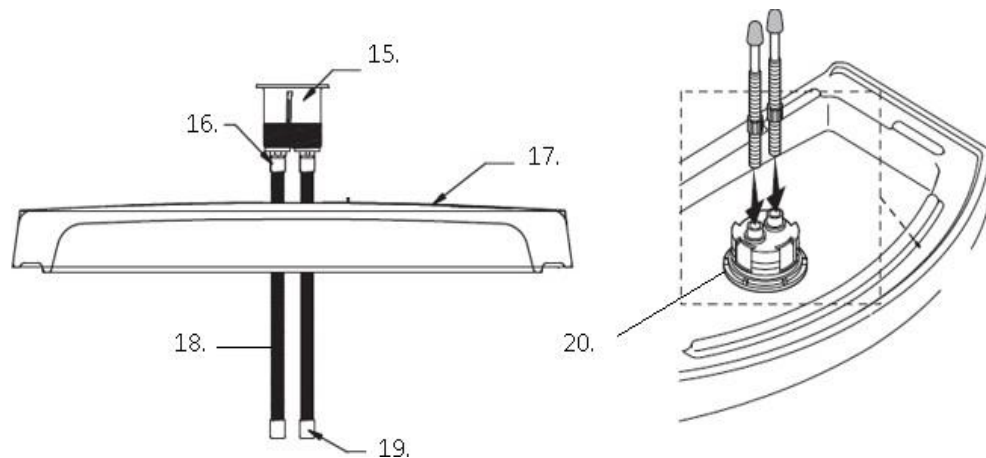

Flushing push button (components below)

- 15. Push button
- 16. Flush rod nut
- 17. Cistern lid
- 18. Flush rods
- 19. Rod rubber sleeve (not included in all models)
- 20. Push button nut
- 21. Syphon including washer, seal and nut (inside cistern part)

Please Note: For toilets which secure through the toilet directly into the floor, the 'L shaped' bracket is not used

Tools required

- Screwdriver
- Pencil
- Drill
- Spirit Level
- Drill Bit
- Hacksaw
- Spanner
- Adjustable grips
- Silicone sealant
- Hammer

Installation

Please note: Before starting any installation, turn off the water supply

Please note: Whenever possible and when safe to do so, it is recommended to carry out leak tests during the installation process

Pan Connector

The pan connector should be prepared for connection to the toilet being installed.

Please note: Pan connector (waste pipe) may need to be purchased separately if a new installation

Depending on your toilet, the pan connector could be installed through the wall, floor right and/or left.

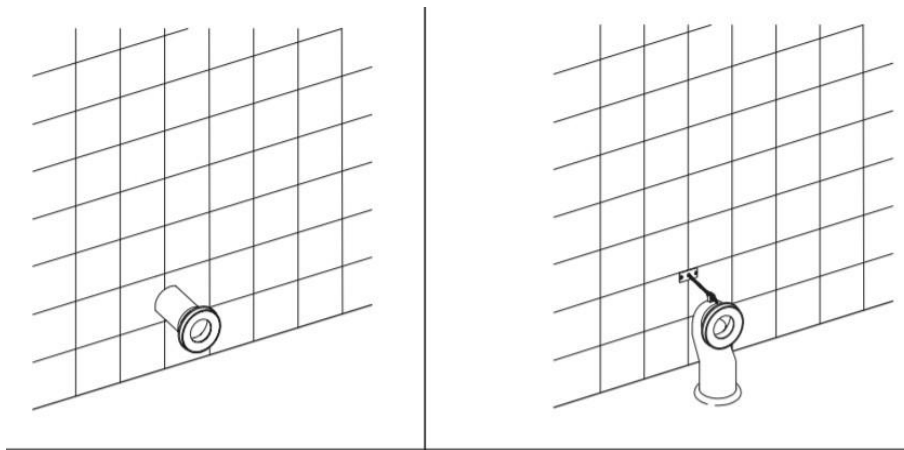

Please note: Pan connector is not included.

Close Coupled Toilet Pan Fitting

1. Once the pan connector pipe is prepared, add a small amount of lubricant (washing up liquid) to the seal, then push the toilet into the require position, with the pan connector fully connected to the soil pipe (spigot).

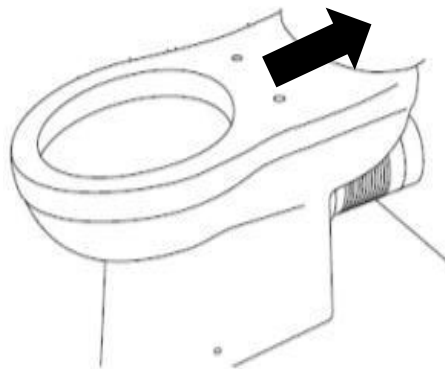

2. Ensure that the toilet pan is level and fully backed against the wall, then mark on the outer edge of the pan (at both sides), align with each fixing hole located in the side wall of the toilet pan.

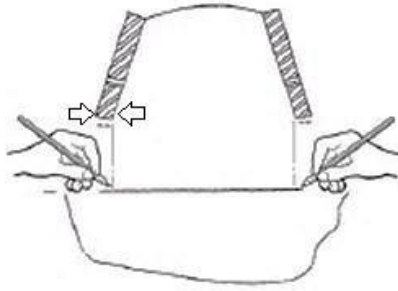

3. Remove the pan from the location, then measure the thickness of the toilet side wall and make another mark in from the original mark, and in line with the fixing hole. Repeat on the other side.

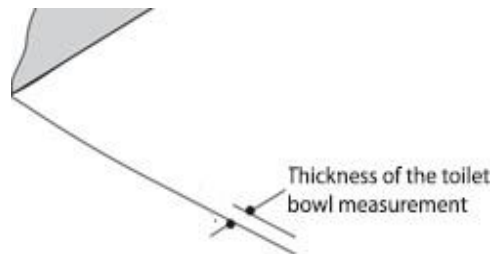

4. If using the 'L' shaped bracket assembly, place the front edge of the bracket on the inside mark, then mark the screw hole position to secure the bracket to the floor. Repeat on the other side.

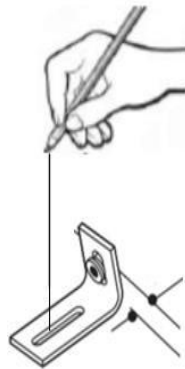

Please Note: For toilets which secure through the toilet directly into the floor, the 'L' shaped' bracket is not used

5. Remove the brackets and drill the holes, ensuring that no pipes or cables can be damaged.

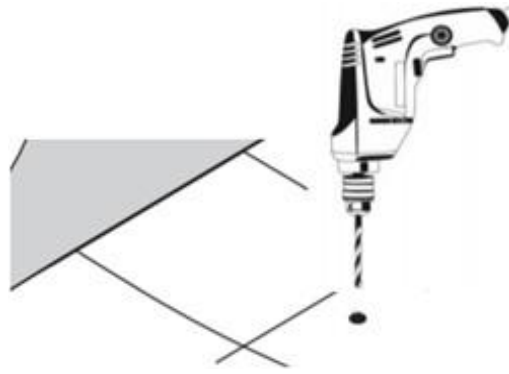

6. If fitting into a solid floor, you will need to install the screw plugs and tap flush to the floor, then place the brackets over the drilled holes/plugs and insert the screws and washers through the brackets and secure into position.

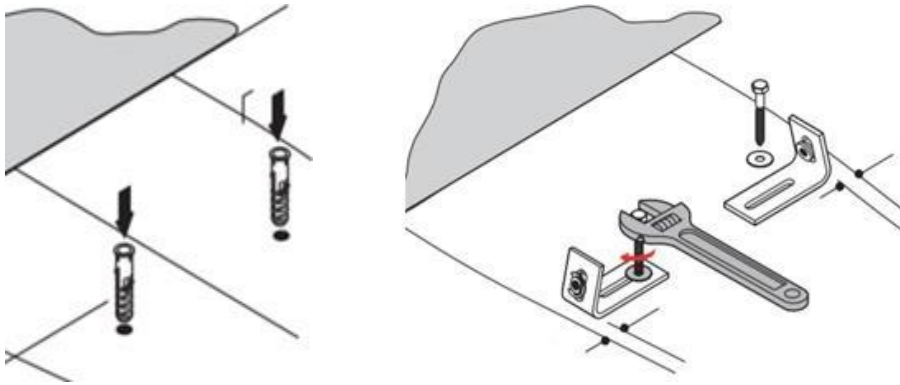

Please note: Depending on the specification, this may be a screwdriver slot, not a spanner fitting

Preparing the Cistern

1. From the inlet valve, remove the nut and washer, (the rubber seal should remain fitted) then place the tail of the inlet valve through the hole in the cistern tank. From underneath the tank re-fit the washer and the nut, do not tighten fully at this stage.

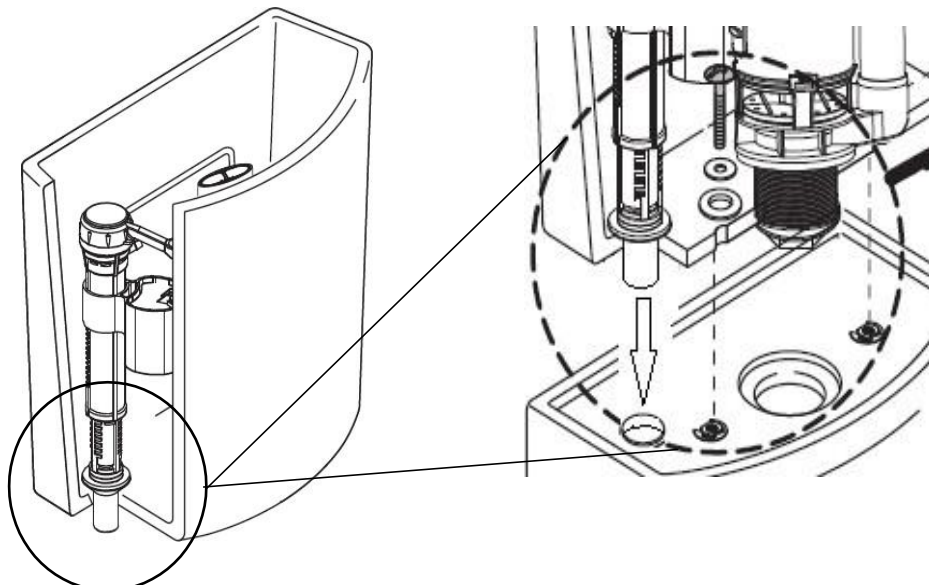

2. Remove the nut from the cistern fixing bolt, then place the bolt, washer and seal into the bottom of the cistern so that the bolt passes through the fixing hole, ensure that the seal sits against the inside face of the tank.

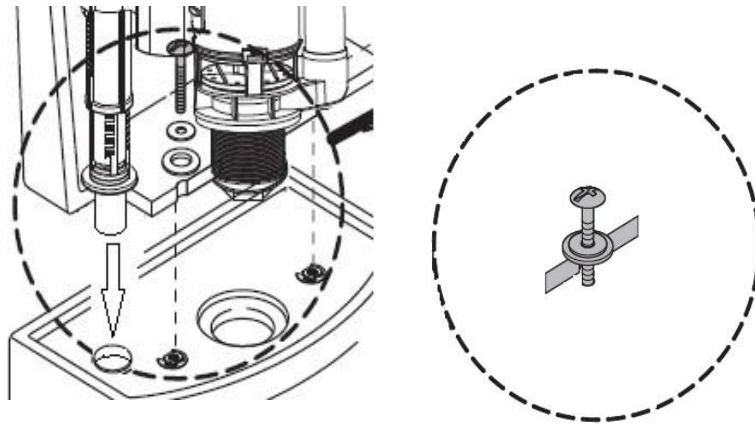

3. Remove the nut and washer from the syphon, then place the threaded tail (syphon) through the hole in the bottom of the cistern. (with the seal against the inside face of the tank) Fit the washer and nut to the syphon thread and tighten, do not use grips as this could deform the syphon.

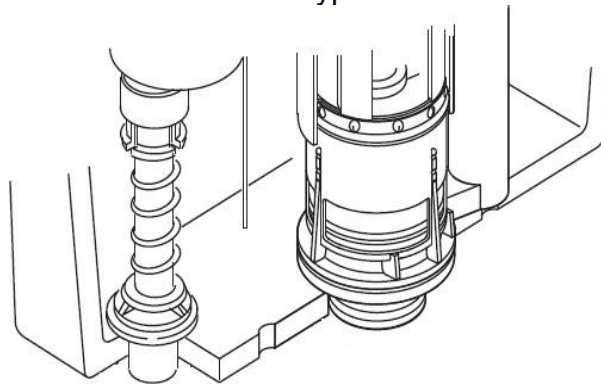

4. Fit the thick doughnut washer to the tail of the syphon and ensure this is fully surrounding the nut.

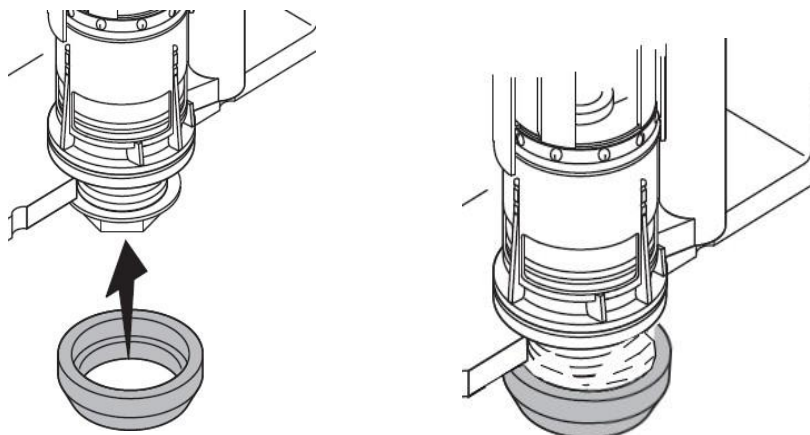

5. Position the cistern tank onto the toilet, allowing the cistern bolts to pass through the holes (1) in the toilet pan, so the inlet valve thread passes through the hole (2) in the toilet pan, and so the doughnut washer sits inside the recess (3).

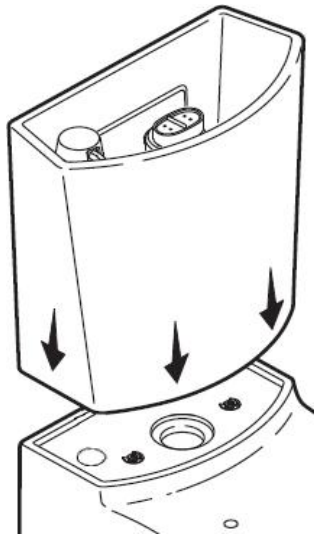

6. From underneath the cistern, fit the nut to the cistern bolt, and using a screwdriver tighten the cistern bolts, do not overtighten.

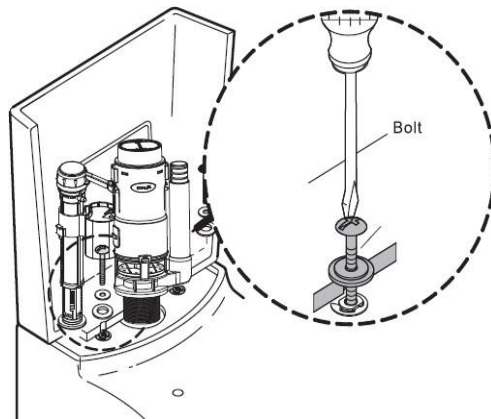

7. From underneath the tank, fit the washer and nut, and tighten, do not overtighten. Connect the water supply pipe which should be a 1/2" female flat-faced connector. Ensure to use a seal.

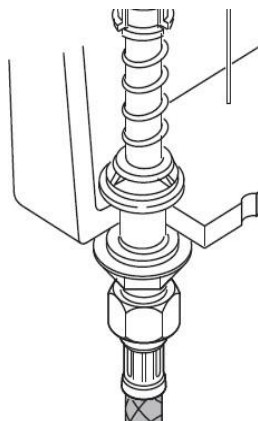

Re-fitting the Toilet Pan

1. After securing the brackets, re-fit the toilet pan and push the waste spigot onto the pan connector, and align the fixing holes with the floor brackets, add a small amount of lubricant (washing up liquid) to assist.

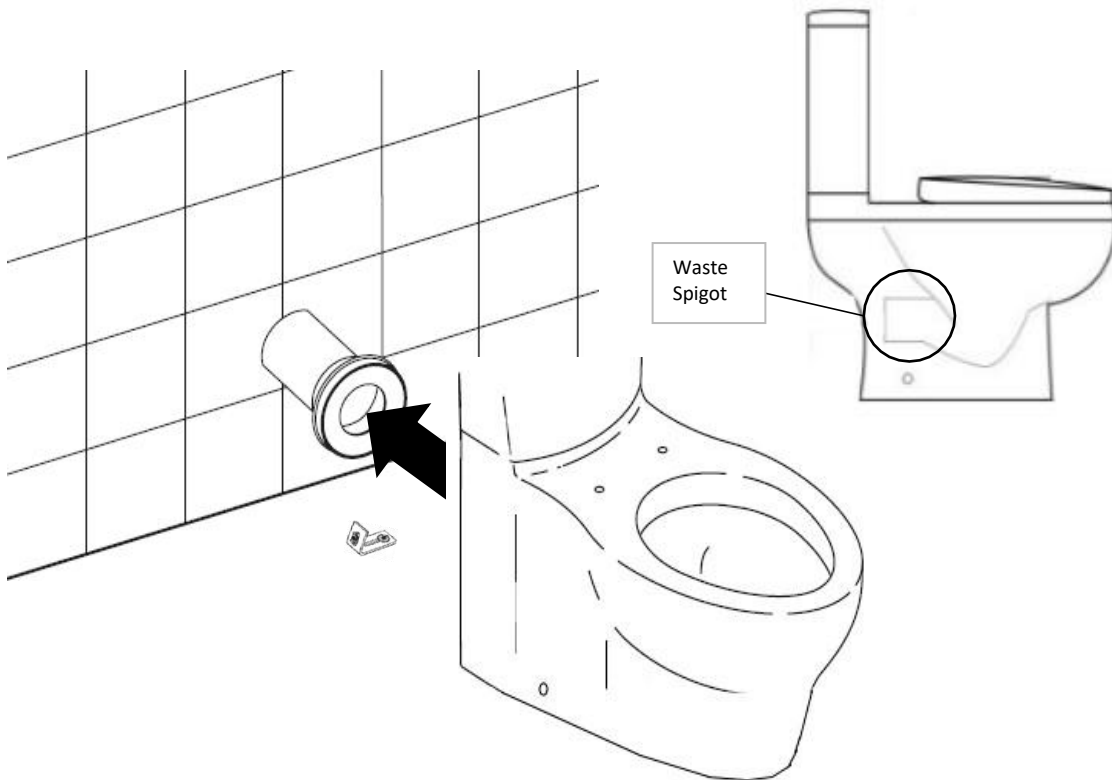

2. Once aligned, secure the toilet pan into position using the fixings provided, do not overtighten. Finish by pushing on the screw covers.

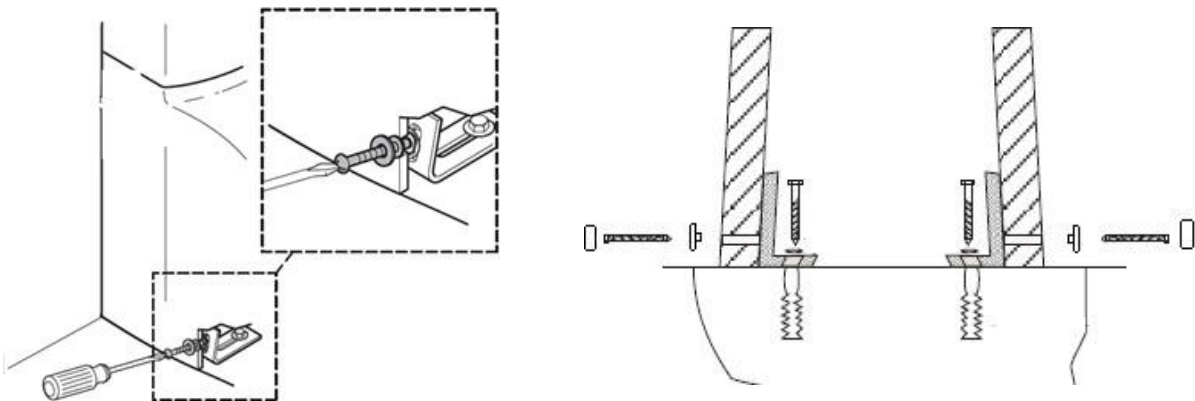

3. Once the installation is completed, a small bead of silicone can be applied around the bottom edge of the toilet pan to finish.

Fitting the Push button

1. Remove the nut from the push button assembly then screw the plastic flush rods into the push button.

Please note: These should be screwed in so that there is a 2 mm minimum gap between the end of the rod and button (on the syphon)

2. Place the assembly through the hole in the cistern lid and fit the lid to the tank, when the rods touch the syphon, measure the height 'H'.
3. Remove the rubber sleeves (not included in all models), then unscrew the rods and cut down by the dimension 'H', at the end that will touch the syphon.
4. Screw the rods back into the push button and refit the rubber sleeves, then fit the nut and tighten, do not overtighten.
5. Place the push button through the hole in the cistern lid, ensuring to align the large button with the full flush button on the syphon, operate several times to ensure correct function.

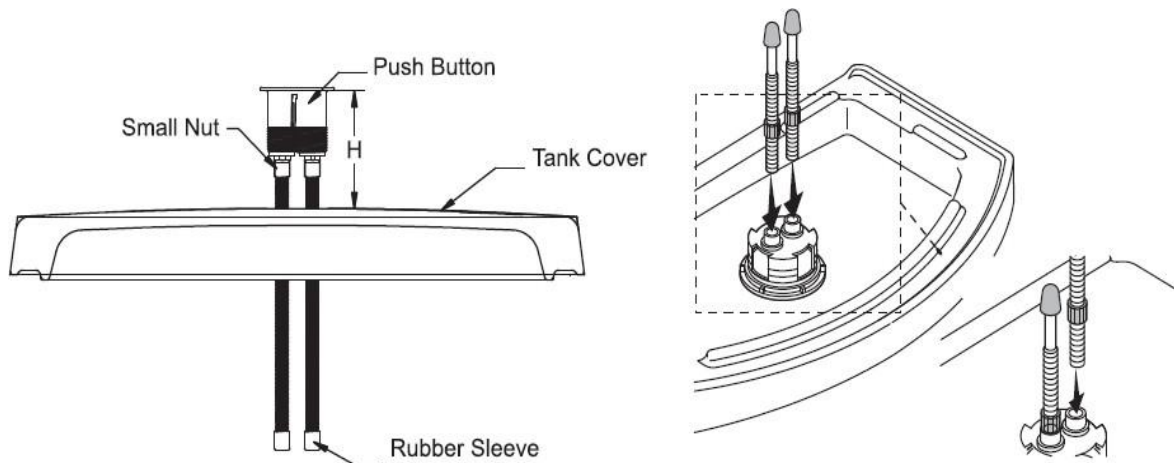

6. Once assembly is completed, turn on water supply, check for leaks and check flush operation.

Troubleshooting

Please note: It is recommended to turn off the water supply via the stop valve before carrying out any internal maintenance

Water continues to run into the toilet pan

Remove the cistern tank lid and determine if the water level reaches the overflow pipe on the syphon; if it does, replace the inlet valve, if it doesn't then replace the upper section of the syphon.

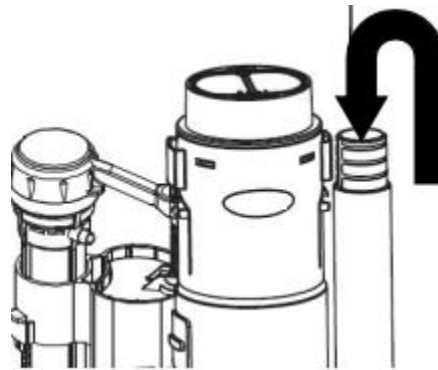

Insufficient or too much water entering the cistern tank

Adjust the inlet valve by turning the adjustment screw, until the desired level is reached.

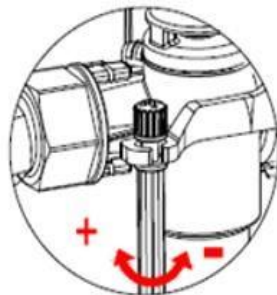

No flush operation when the push button is pressed

Remove the cistern tank lid and press the two buttons on top of the syphon. If the cistern flushes 'normal', replace the push button or check that the rods have not been screwed into the push button too far, (that they're not reaching the buttons when pressed).

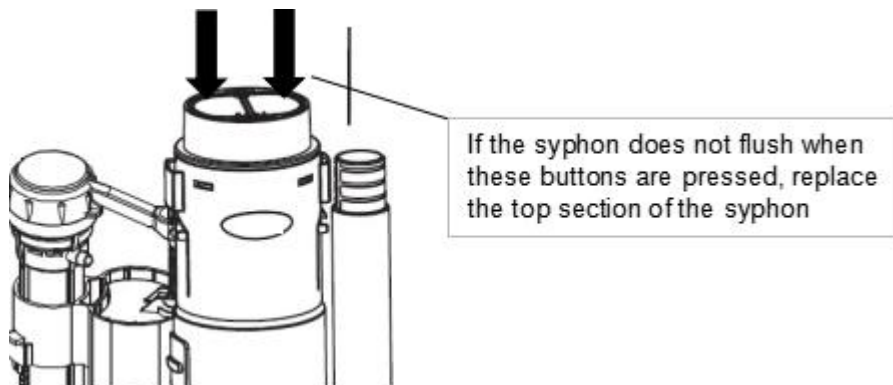

Maintenance

Please note: Turn off the water supply and flush the toilet to drain away the water in the tank, it is also recommended to have a bucket under the tank to catch draining water

Please note: Depending on the toilet design you may need to remove the toilet pan from its location to access the inlet valve water supply nut and retaining nut

To replace the inlet valve

Disconnect the water supply from the inlet valve, then remove the inlet valve by unscrewing the nut on the underside of the cistern tank and remove the cistern tank lid and pull the inlet valve from the tank. Once replaced, ensure all seals are re-fitted.

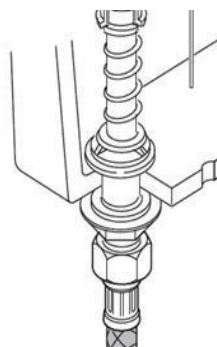

To replace the syphon

This should only require the top section to be replaced. Grab the syphon and turn anti-clockwise and then lift. Upon replacing, ensure that the syphon clicks back into position and the flush buttons are aligned with the correct button on the syphon.

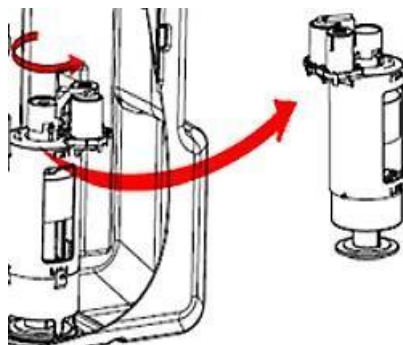

Cleaning

To maintain the surface finish of your product, wipe clean after every use, using a clean damp cloth, a mild detergent mixture can be used. Do not use abrasive cleaning agents or materials which can strip and scratch the surface; the use of these agents or materials can invalidate your guarantee.